

C:\USERS\VEROICHE\ONEDRIVE - SUBMAR\ENG\_DEPT\AUTOCAD\DETAILS\UPDATED FRAMES (02.04.25)\OS\40' DUAL RELEASE (CAD)\REV. 3\40 FT OS DRDF\_REV 3

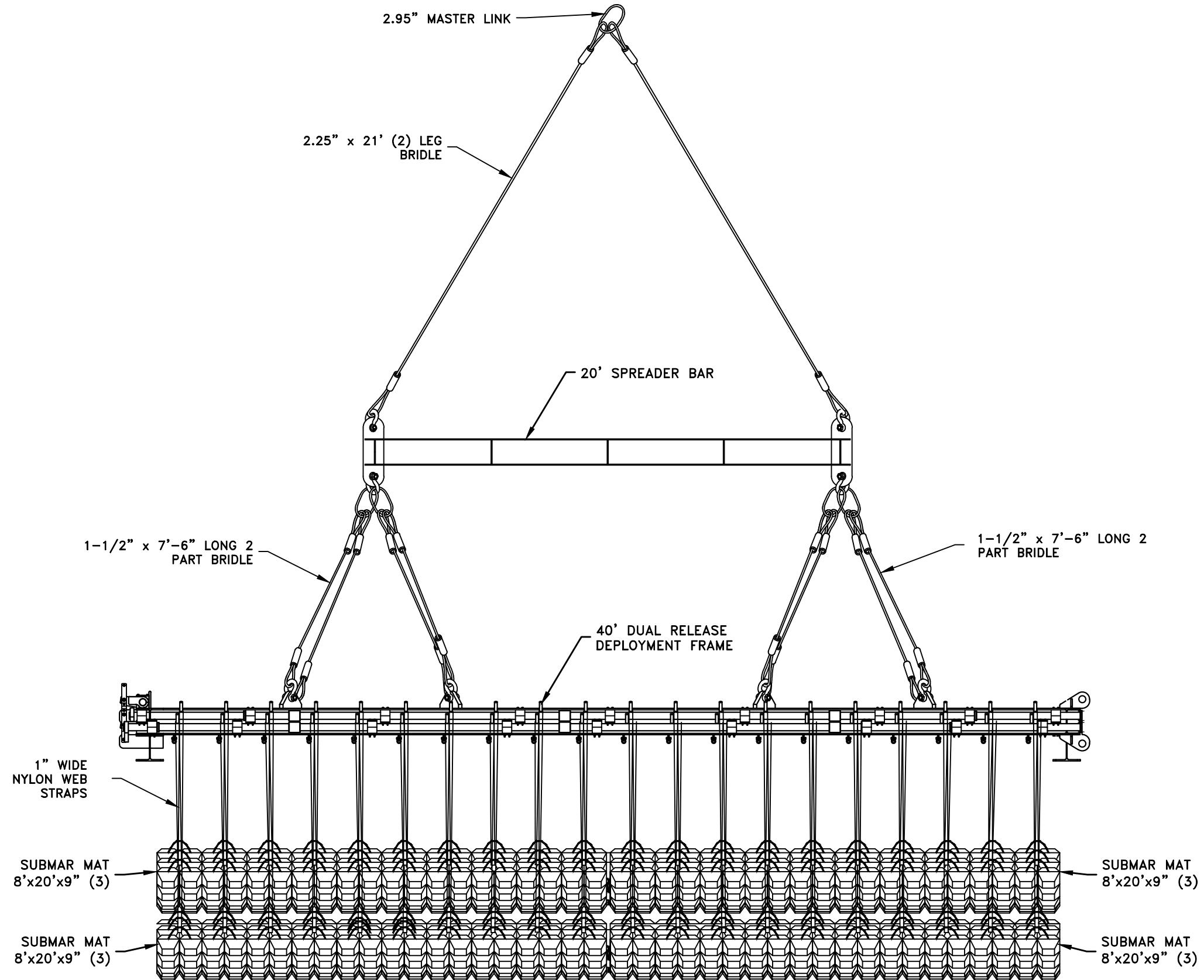
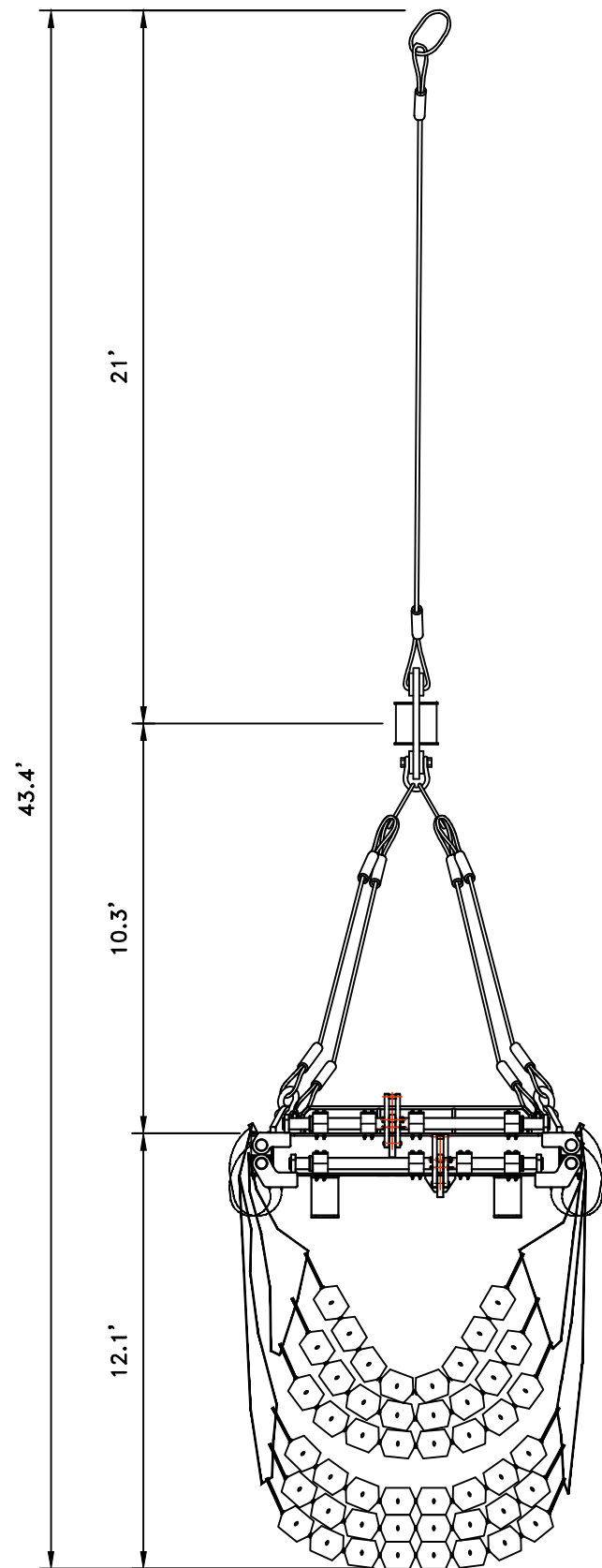

THESE CONCEPTUAL DRAWINGS ARE PREPARED BY SUBMAR FOR ESTIMATING PURPOSES ONLY AND ARE NOT CONSTRUCTION DRAWINGS. THESE CONFIDENTIAL DRAWINGS MAY NOT BE COPIED UNLESS APPROVED BY SUBMAR, INC. COPYRIGHT © SUBMAR, INC. 2026 ALL RIGHTS RESERVED.

SCALE: N.T.S.

SPECIFICATIONS		
	IMPERIAL	METRIC
DIMENSIONS	9.25'x42'x5.33'	2.8mx12.8mx1.62m
FRAME EMPTY WEIGHT (W/ RIGGING, SPREADER BAR, AND HANGING COMPONENTS)	28,400 lbs.	12.88 mt
WORKING LOAD LIMIT (WLL)	63 tn	57.15 mt

**SUBMAR®**  
 104 ROYAL OAK BLVD  
 THIBODAUX, LA 70301  
 PH. 985-868-0001  
 WEBSITE: WWW.SUBMAR.COM

No.	REVISION DESCRIPTION	DATE
1	REVISED SHEET INFO	02/04/25
2	REVISED SHEET INFO	04/22/25
3	REVISED SHEET INFO	03/15/26

DATE: 01/09/2024	DWN: KJD
PROJECT No:	CHK: JMF

40' DUAL RELEASE  
 DEPLOYMENT FRAME

SHEET TITLE:  
 OVERALL ASSY

SHEET No:  
 OS-40DRMF-104

C:\USERS\VEROICHE\ONEDRIVE - SUBMAR\ENG\_DEPT\AUTOCAD\DETAILS\UPDATED FRAMES (02.04.25)\05'40' DUAL RELEASE\CAD\REV. 3\40 FT OS DRDF\_REV 3

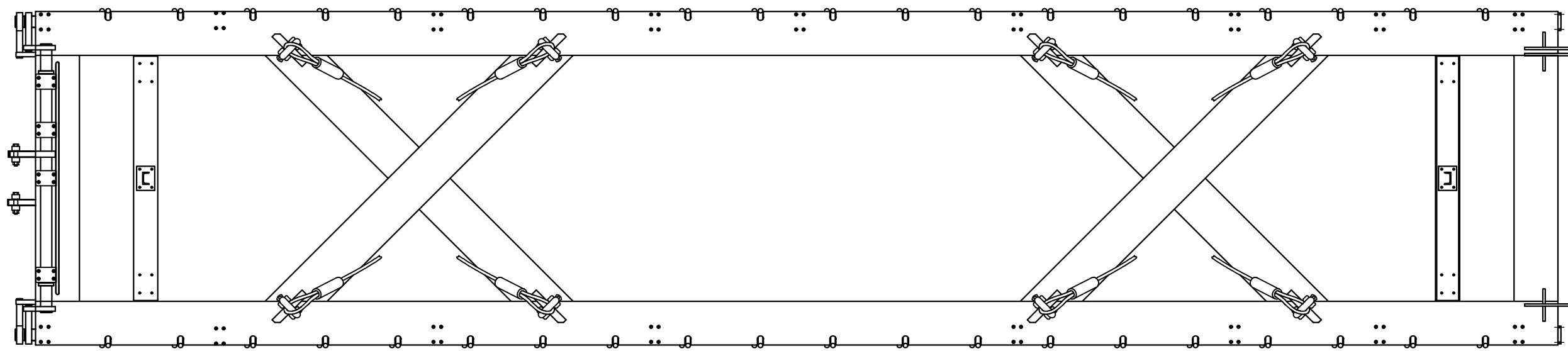

PLAN VIEW

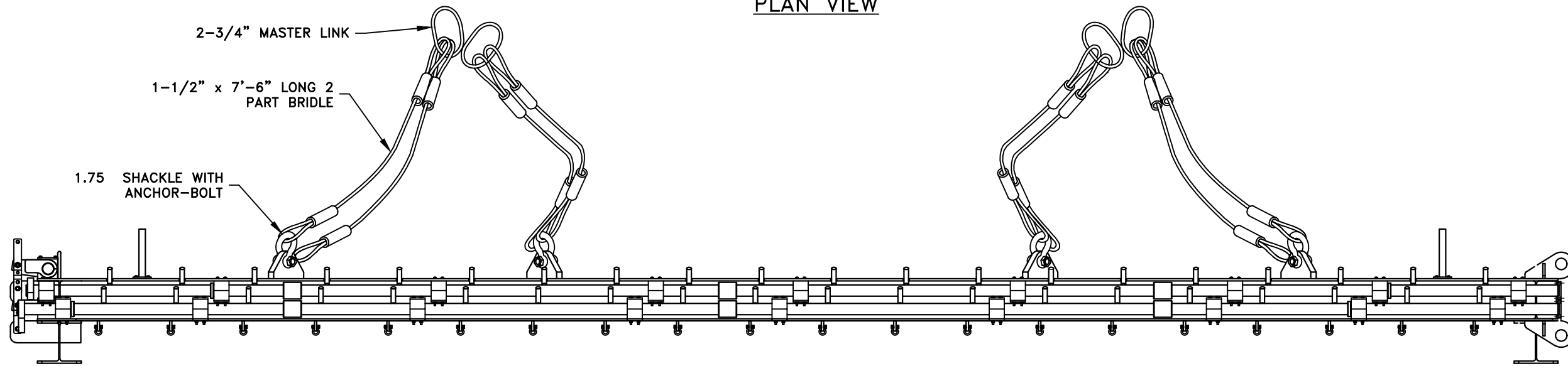

SIDE VIEW

2-3/4" MASTER LINK

1-1/2" x 7'-6" LONG 2 PART BRIDLE

1.75 SHACKLE WITH ANCHOR-BOLT

2-3/4" MASTER LINK

2 PLY - TYPE 3 1" x 18' W/ 12" EYE EACH END NYLON SLINGS

2 PLY - TYPE 3 1" x 12' W/ 12" EYE EACH END NYLON SLINGS

LEFT END VIEW

MATERIAL LIST	
QTY	DESCRIPTION
8	1.75" SHACKLE 25T
80	.5 SHACKLE W/ ANCHOR BOLT
40	1" x 12" 2 PLY STRAPS
40	1" x 18" 2 PLY STRAPS
4	1-1/2" x 7'-6" 2 PART BRIDLE
4	2-3/4" MASTER LINK

SPECIFICATIONS		
	IMPERIAL	METRIC
DIMENSIONS	9.25'x42'x5.33'	2.8mx12.8mx1.62m
FRAME EMPTY WEIGHT (W/ RIGGING)	25,800 lbs.	11.70 mt
WORKING LOAD LIMIT (WLL)	63 tn	57.15 mt

THESE CONCEPTUAL DRAWINGS ARE PREPARED BY SUBMAR FOR ESTIMATING PURPOSES ONLY AND ARE NOT CONSTRUCTION DRAWINGS. THESE CONFIDENTIAL DRAWINGS MAY NOT BE COPIED UNLESS APPROVED BY SUBMAR, INC. COPYRIGHT © SUBMAR, INC. 2026 ALL RIGHTS RESERVED.

SCALE: N.T.S.

**SUBMAR®**

104 ROYAL OAK BLVD  
THIBODAUX, LA 70301  
PH. 985-868-0001  
WEBSITE: WWW.SUBMAR.COM

No.	REVISION DESCRIPTION	DATE
1	REVISED SHEET INFO	02/04/25
2	REVISED SHEET INFO	04/22/25
3	REVISED SHEET INFO	03/15/26

DATE: 01/09/2024	DWN: KJD
PROJECT No:	CHK: JMF

40' DUAL RELEASE  
DEPLOYMENT FRAME

SHEET TITLE:

FRAME ASSY

SHEET No:

OS-40DRMF-105